



GX9

Features:

- High performance axial fan for extract & intake.
- Remote switch (not supplied) starts fan and opens internal back draught shutter for extract or intake.
- Internal fan selector switch sets the fan to intake (1) extract (2) & controller (3).
- Silent Shutter Operation via a thermal actuator.
- Trickle ventilation facility for background ventilation when not in use.
- High performance axial flow fan providing both extract and intake GX9.
- Stylish design and white appearance to complement and blend with modern décor.
- Silent shutter operation via thermal actuator.
- Clip off front cover for sleek appearance and easy cleaning.
- Trickle ventilation facility for background ventilation when not in use.
- Finger guarded front grille.
- Totally enclosed motor fitted with thermal cut out requires no maintenance.
- Comprehensive range of ancillaries and controllers available.
- 3 Year guarantee (UK - ONLY).
- Export Customers see your Local Distributor.



Performance:

GX9 is operated by a remote switch (not supplied), or a controller available as an ancillary.

| | |
|---------------------------------|---|
| Sound Pressure (dB(A)): | 50 |
| Extraction (m ³ /h): | 720 (200.00 l/s) |
| Intake (m ³ /h): | 465 (129.17 l/s) |
| Power (W): | 45 |
| Mounting: | Wall, Window, Roof Fan |
| Usage: | Kitchen, Pub, Restaurant, Office, Factory, Shop |





Dimensions

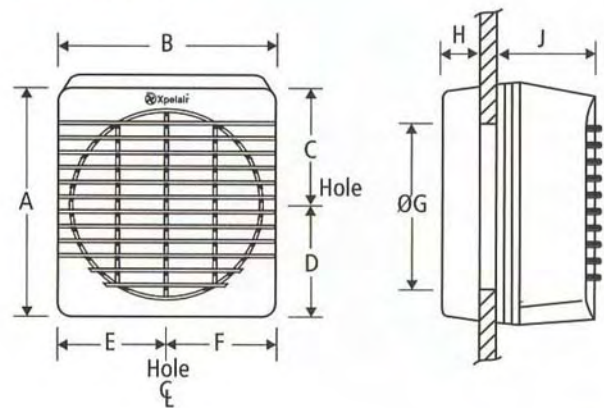

| | GX9 |
|--------------------|-----|
| A | 312 |
| B | 294 |
| C | 165 |
| D | 147 |
| E | 147 |
| F | 147 |
| G Window hole dia. | 257 |
| H | 32 |
| J | 117 |
| Weight (Kg) | 4.0 |





GX9

Performance

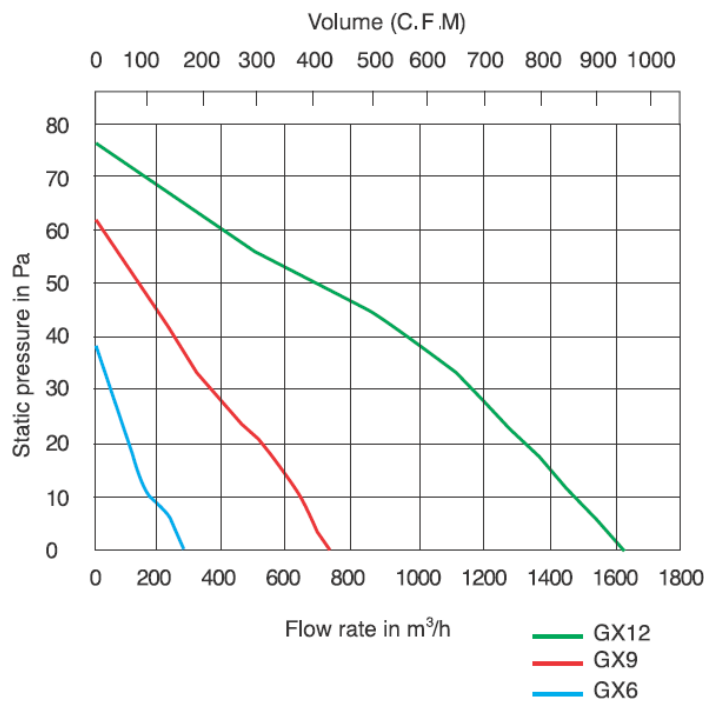

Wiring Diagram

Xpelair GX9 & GX12

GX9/GX12

