



GX12

Features:

High performance axial flow fan providing both extract and intake
GX9/GX12 extract only GXC9.
Stylish design and white appearance to complement and blend with modern décor.
Silent shutter operation via thermal actuator.
Clip off front cover for sleek appearance and easy cleaning.
Trickle ventilation facility for background ventilation when not in use.
Finger guarded front grille.
Totally enclosed motor fitted with thermal cut out requires no maintenance.
Comprehensive range of ancillaries and controllers available.
3 Year guarantee (UK - ONLY).
Export Customers see your Local Distributor.



Performance:

GX12 are operated by a remote switch (not supplied), or a controller available as an ancillary.

Sound Pressure (dB(A)):	54.5
Extraction (m ³ /h):	1620 (450.00 l/s)
Intake (m ³ /h):	1200 (333.33 l/s)
Power (W):	90
Mounting:	Wall, Window, Roof Fan
Usage:	Kitchen, Pub, Restaurant, Office, Factory, Shop





Dimensions

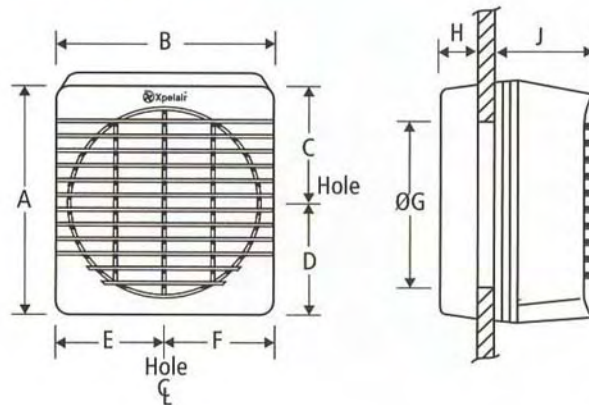

	GX12
A	408
B	380
C	216
D	192
E	190
F	190
G Window hole dia.	324
H	34
J	161
Weight (Kg)	7.9





GX12

Performance

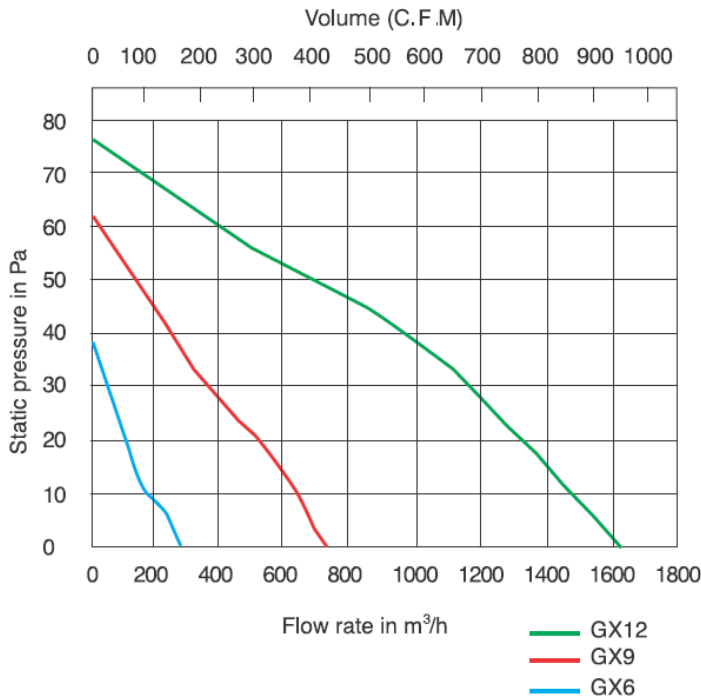

Wiring Diagram

Xpelair GX9 & GX12

GX9/GX12

